

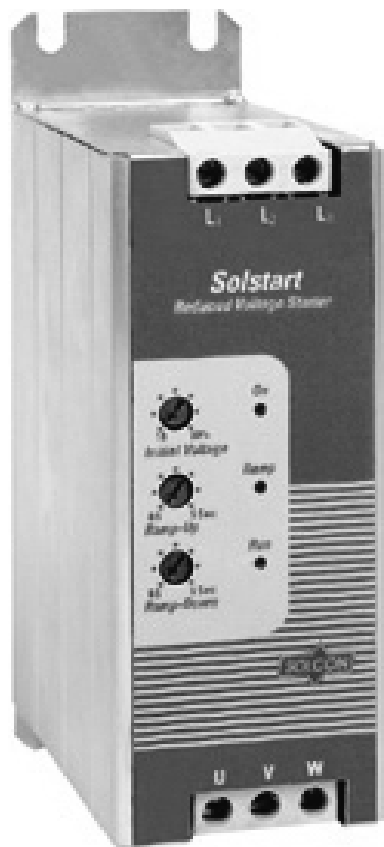

# Solstart

Miniature Soft Starter  
8-58A, 220-600V



## Instruction Manual

Ver. 21.2. 2002

# Table of Contents

---

<b>Page</b>	<b>Subject</b>
3	Starter Selection
4	Installation Notes
5	Wiring
6	Starter Settings & Start-up Procedure
7	Dimensions
8	Technical Specification

## Safety



- Read this manual carefully before operating the equipment and follow its instructions.
- Installation, operation and maintenance should be in strict accordance with this manual, national codes and good practice. Installation or operation not performed in strict accordance with these instructions will void manufacturer's warranty.
- Disconnect all power inputs before servicing the soft-starter and/or the motor.
- Prior to the installation, check and verify that no parts (bolts, washers, etc) will fall into the starter.

## Attention

1. This product was designed and tested for compliance with IEC 947-4-2 for class A equipment.
2. Use of the product in domestic environments may cause radio interference, in which case the user may be required to employ additional mitigation methods.
3. Utilization category is AC-53a or AC53b. Form1.
4. For further information see Technical Specification.

## Warnings



- Internal components and P.C.B's are at Mains potential when the Solstart is connected to mains. This voltage is extremely dangerous and may cause death or severe injury if contacted.
- When the Solstart is connected to Mains, even if start signal has not been issued, full voltage may appear on motor's terminals. Therefore, for isolation purposes it is required to connect an isolating device (C/B, switch, line contactor, etc) upstream to the Solstart.
- Starter must be properly grounded (except 8-22A) to ensure correct operation and safety.  
Check that Power Factor capacitors are not connected to the output side of the soft starter

The company reserves the right to make any improvements or modifications to its products without prior notice.

# Starter Selection

The Solstart is a Miniature Analogue soft starter which incorporates two sets of thyristors to start a three phase squirrel cage induction motor. By supplying a slowly increasing voltage, it provides soft start and smooth stepless acceleration, while drawing the minimum current necessary to start the motor.

A Soft Stop feature can be enabled when the Ramp-Down potentiometer is adjusted. When used, upon stop signal (open contact terminals 1 and 2), starter's output voltage is slowly reduced to zero.

## Soft-Start Characteristics

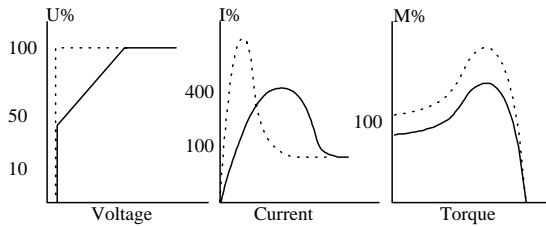

## Soft-Stop Characteristics

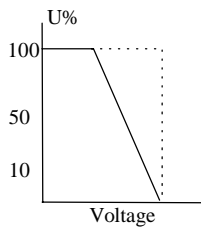

Used for controlled deceleration of pumps and high friction loads.

## Solstart Ratings and Frame Sizes

Max. Motor FLA (Amp)	Starter Type FLC(Amp.)	Frame Size
8	Solstart 8	S1
17	Solstart 17	S2
22	Solstart 22	
31	Solstart 31	S3
44	Solstart 44	
58	Solstart 58	

## Dimensions (mm) & Weights (Kg)

Size	Width	Height	Depth	Weights (Kg)
S1	45	75	110	0.42
S2	90	75	105	0.55
S3	65	190	114	1.3

The starter should be selected in accordance with the following criteria:

### 1. Motor Current & Starting Conditions

Select the starter according to motor's Full Load Ampere (FLA) - as indicated on its nameplate (even if the motor will not be fully loaded).

The Solstart is designed for operation of:

3.5 x In, for 5 Sec. at 40°C.

Max. Starts per Hour: 4 starts per hour at maximum ratings. Up to 10 starts per hour at light load applications (consult factory).

**Note:** For very frequent starts (inching applications) the inching current should be considered as the Full Load Current (FLC) – consult factory.

### 2. Mains Voltage

Each starter is factory set for one of the following levels according to the Ordering Information.

Voltage	Tolerance
220 - 240 V	+10 -15 %
380 - 415 V	+10 -15 %
440 V	+10 -15 %
460 - 500 V	+10 -15 %
575 - 600 V	+10 -15 %

Frequency: 50 / 60 Hz.

# Installation Notes

## Prior to Installation

Check that Motor's Full Load Ampere (FLA) is lower than or equal to starters Full Load Current (FLC) and that Mains voltage is equal to the rated voltage of the starter.

## Mounting

- The starter must be mounted vertically. Allow sufficient space above and below the starter for suitable airflow.
- It is recommended to mount the starter directly on the rear metal plate of the switchgear for better heat dissipation.
- Do not mount the starter near heat sources.
- Protect the starter from dust and corrosive atmospheres.

## Temperature Range and Heat Dissipation

The starter is rated to operate over a temperature range of  $-10^{\circ}\text{C}$  ( $14^{\circ}\text{F}$ ) to  $+40^{\circ}\text{C}$  ( $104^{\circ}\text{F}$ ).

Relative non-condensed humidity inside the enclosure should not exceed 93%.

The heat dissipation during continuous operation is Approx.  $0.3 \times I_n$  (in watts).

**Example:** When motor's current is 17 Amp, heat dissipation will be approx. 5.1 watts.

Internal enclosure heating can be reduced through the use of additional ventilation.

## Additional Ventilation

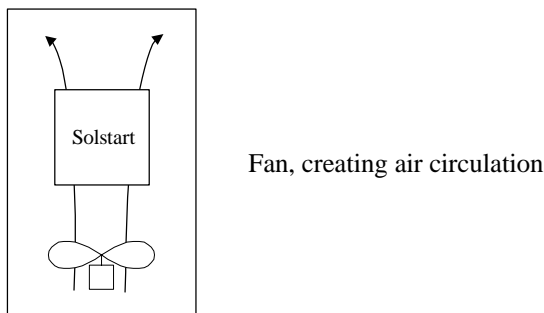
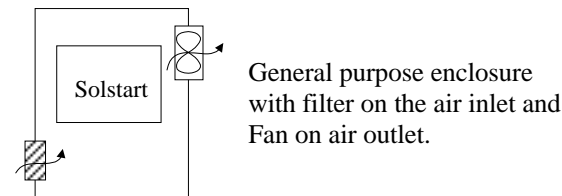

## Voltage Spike Protection

Voltage spikes can cause malfunction of the starter and damage the SCRs. When expected, use suitable protection such as Metal Oxide Varistors (consult factory for further details).

## Short Circuit Protection

The Solstart should be protected against a short circuit by Thyristor Protection fuses.

The recommended  $I^2t$  values are:

Solstart Type	$I^2t$
Solstart 8	400
Solstart 17	2000
Solstart 22	2500
Solstart 31	3000
Solstart 44	6000
Solstart 58	12000

### Caution

Power factor correction capacitors must not be installed on starter's Load side. When required, Install capacitors on the Line side.

### Warning

When Mains voltage is connected to the starter, even if start signal has not been initiated, full voltage will appear on the starter's load terminals. Therefore, for isolation purposes it is required to connect an isolating device (C/B, switch, line contactor, etc) upstream to the Solstart (on the Line Side).

## Built-in Bypass

The Solstart incorporates two internal bypass relays allowing current flow through the thyristors only during starting process. At the end of the starting process the built-in relays bypass the thyristors and carry the current to the Motor.

Upon stop signal, or in case of fault, the bypass relays will open and stop the motor.

When Ramp-Down potentiometer is set to allow soft-Stop process, upon stop command, the bypass relays will open immediately and the current will flow through the thyristors. The voltage will then be reduced slowly and smoothly to zero.

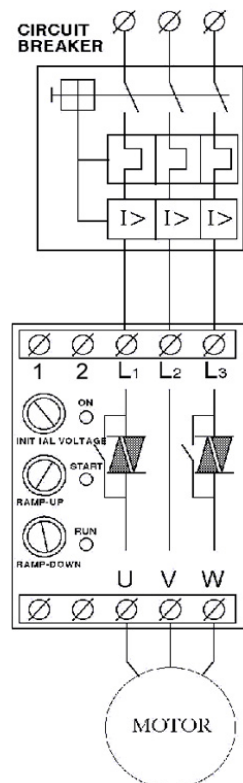

# Wiring

## Block and Connection Diagram

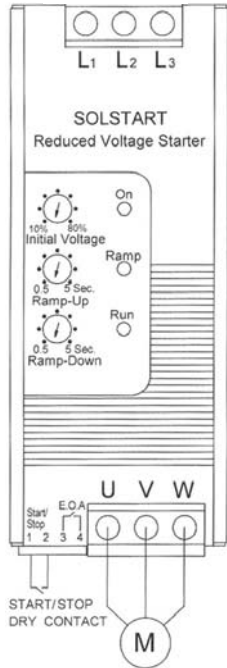

**Stop / Start..... Terminals 1 - 2**  
 By voltage free contact (Dry contact)  
 Close: Start command.  
 Open : Stop command.

**Warning**

Do not apply voltage to terminals 1 - 2.

**End of Acceleration (E.O.A) ..... Terminals 3 - 4**  
 EOA relay exists only in starters 31-58A.  
 Voltage free, N.O., 5A / 250VAC, 2000VA max.,  
 The contact closes after the time adjusted on the "Ramp-Up" potentiometer. The contact returns to its original position on stop signal, on fault condition, upon voltage outage and at the beginning of Soft Stop.

**Warning**

Start/Stop with a maintained contact !

When the line contactor is operated by a maintained contact, in case of Mains failure, the motor will be automatically restarted upon voltage restoration.

## Connection Diagram

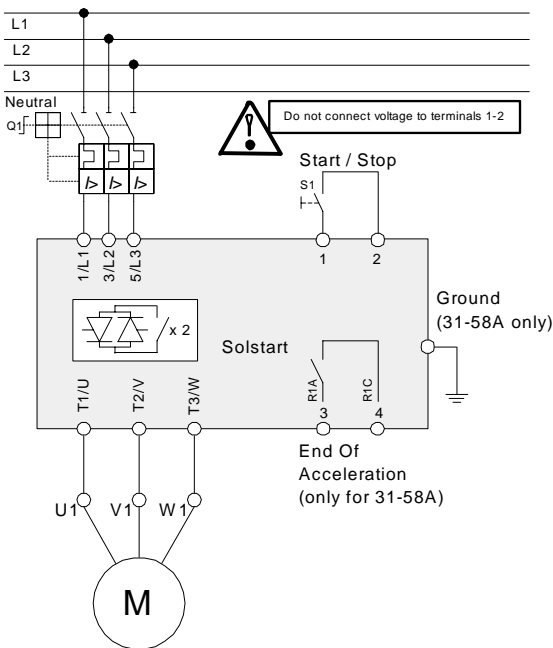

# Setting & Startup Procedure

## Front Panel Layout

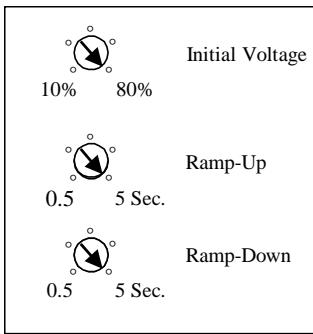

### Initial Voltage

Determines the initial voltage to the motor (The torque is directly proportional to the square of the voltage).  
Range : 10-80% of nominal voltage.

This adjustment also determines the inrush current and mechanical shock.

Too high of a setting may cause high initial mechanical shock and high inrush current.

Too low of a setting may result in prolonged time until motor starts revolving. The motor should start revolving immediately after Start signal.

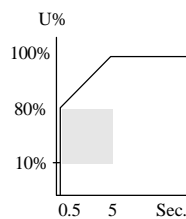

### Ramp-up Time

Determines motor's voltage ramp-up time from initial to full voltage.  
Range: 0.5-5 sec.

It is recommended to set Ramp-Up Time to the minimum acceptable value.

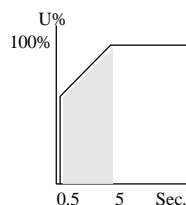

### Ramp-Down time (Soft-stop)

Used to control deceleration of high friction loads. When Ramp-Down potentiometer is set, upon stop signal the starter output voltage is gradually ramped down.

Range: 0.5-5 sec.

When "Ramp-down Time" is set to minimum (0.5Sec), the motor will stop immediately.

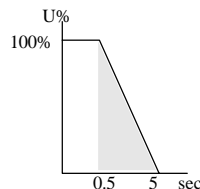

## Startup Process

1. Set Initial Voltage potentiometer to mid scale (approx. 40%)
2. Set Ramp-Up potentiometer to approx. 3 sec.
3. Connect Mains voltage to starter Line terminals.
4. Start the motor. If it begins revolving shortly after start signal proceed to Para. 5. If not, increase Initial Voltage setting until motor starts to turn shortly after start signal.
5. When initial inrush current and mechanical shock are too high, decrease Initial Voltage setting and proceed to paragraph 6.
6. Disconnect the start command (open Terminals 1 and 2) and wait until the motor stops.
7. Slightly increase Initial Voltage adjustments to allow for load variations.
8. Start the motor again and verify that acceleration process to full speed is as required.
9. If acceleration time is too short, increase Ramp-Up time setting.

When Soft stop is required, set Ramp-Down Potentiometer to the required time (minimum deceleration time is recommended).

Check that soft stopping process is as required.

### Note:

If Ramp Down potentiometer is not in the minimum setting. Emergency stop may be performed by disconnecting the mains voltage.

### Example of Starting Curves

Light Loads - Pumps, Etc.

Initial Voltage - set 40%

Ramp-up time - set 3 sec.

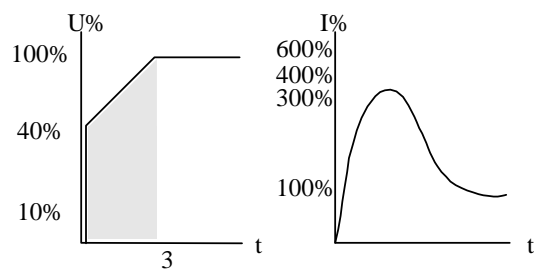

Upon start, the voltage quickly increases to the Initial Voltage value (40%  $U_n$ ) and then gradually ramps-up to nominal.

The current will simultaneously increase to peak current value, before smoothly decreasing to the operating current. Motor will quickly and smoothly accelerate to full speed.

# Dimensions & Weights

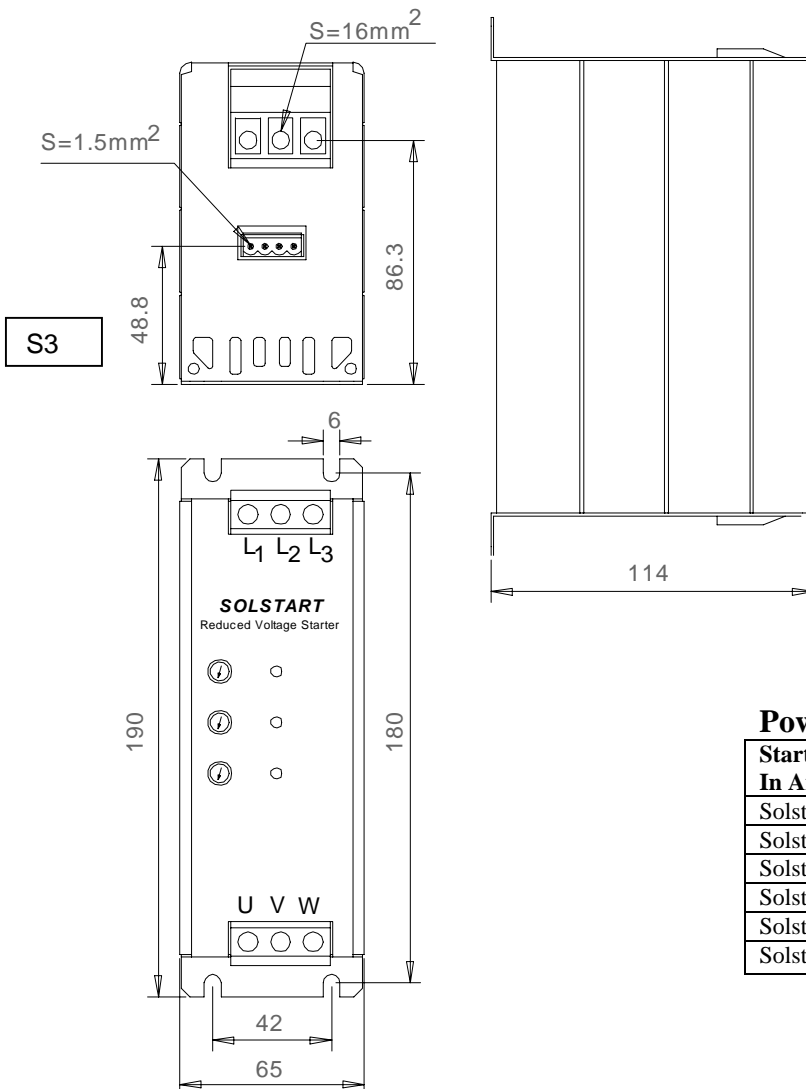
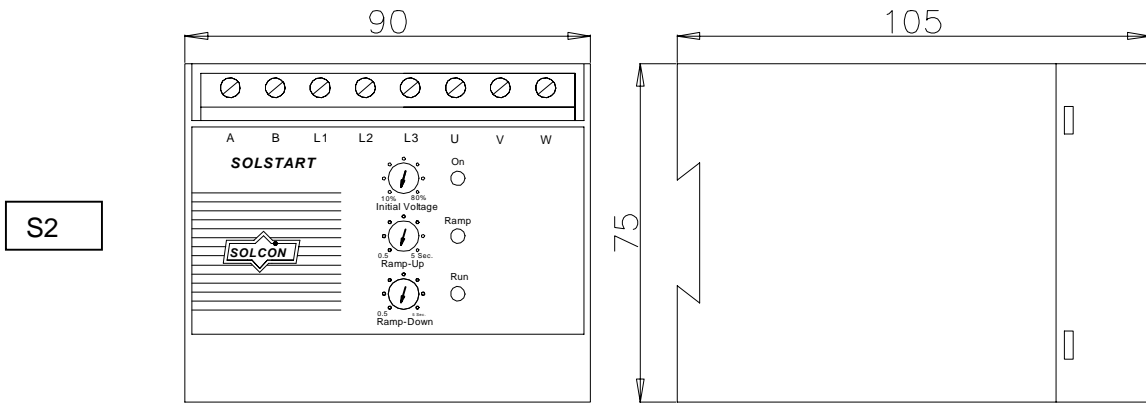
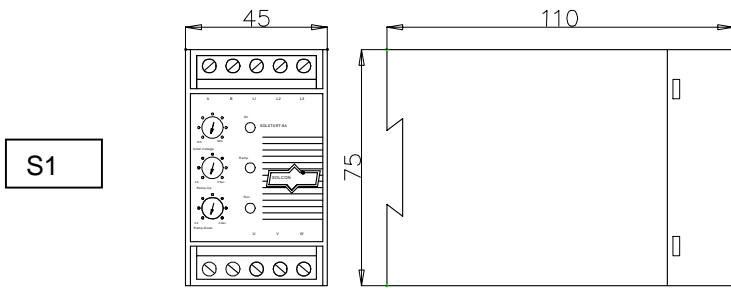

## Power & Control Connections

Starter Type In Ampere	Size	Power Connections	Control Connections
Solstart 8	S1	Terminals 4 mm <sup>2</sup>	Terminals 1.5 mm <sup>2</sup>
Solstart 17 Solstart 22	S2		
Solstart 31 Solstart 44 Solstart 58	S3	Terminals 16 mm <sup>2</sup>	

# Technical Specifications

<b>Environment</b>		
Supply voltage	Three phase, line to line, 220 – 240 Vac +10% -15% 380 – 415 Vac +10% -15% 440Vac +10% -15% 460 – 500 Vac +10% -15% * 575 – 600 Vac +10% -15%	
Frequency	50 / 60 Hz	
Load	Three-Phase, Three-Wire, Squirrel Cage Induction Motor	
Degree of protection	IP 20	
Altitude	1000 m above sea level	Consult factory for derating
<b>Adjustments</b>		
Starting Torque (Initial Voltage)	10-80 % of full voltage	
Ramp Up Time (soft start)	0.5 - 5 sec.	
Ramp Down Time (Soft Stop)	0.5 - 5 sec.	
Indication light (LED)	ON – Green	Lights when mains is connected to the Solstart.
	Ramp Up/Down – Yellow	Lights during Ramp-Up and Ramp-Down
	Run - Green	Lights after end of starting process
<b>Temperatures</b>		
Operating	-10° to 40°C	
Storage	-20° to 70°C	
Relative humidity	93 % - non condensed	
<b>EMC</b>		
Immunity to radio electric interference	EN 1000-4-3 level 3	Conforming to EN 60947-4-2
Electrostatic discharge	EN 1000-4-2 level 3	Conforming to EN 60947-4-2
Immunity to electrical transients	EN 1000-4-4 level 4	Conforming to EN 60947-4-2
Shock waves of voltage / current	EN 1000-4-5 level 3	Conforming to EN 60947-4-2
Radiated and conducted emissions	EN 1000-4-6 level 3	
Radio frequency emissions	According to EN 55011 class A	Conforming to EN 60947-4-2
<b>Mechanical</b>		
Shock resistance	8 gn	Conforming to EN 60947-4-2
Vibration resistance	2 gn	Conforming to EN 60947-4-2
<b>Output relay – ( Starters 31-58A only)</b>		
End of Acceleration Contact	N.O.	
Rated operating current	5 A, 250 V	